



### Background – the M1 Abrams:

The M1 tank is named for former Army Chief of Staff General Creighton Abrams, commander of the US military forces in Vietnam from 1968 to 1972. Designed as a replacement for the M60 Patton tank, the first prototypes were developed by Chrysler and General Motors in 1976. As the new tank was to be turbine powered, the Chrysler prototype was chosen for production to take advantage of the company's extensive experience with land based turbine powered vehicles.

The tank entered service with the US Army as the M1 Abrams in 1980, with a total of 3,200 vehicles produced from 1979 to 1985. The multi-fuel turbine engine can run on diesel, kerosene, any grade of gasoline, and JP-4 and JP-8 jet fuel. The vehicle features composite armour, protection from nuclear, chemical, and biological weapons, and carries its ammunition in a special blow-out compartment that vents outboard to protect the crew. It is operated by a crew of four, weighs 68 tons, and can achieve 66 kmh. The main gun is the Royal Ordnance 105mm gun, produced under license. The vehicle can also be fitted with mine roller or mine plow attachments. The tank has been exported to Egypt, Kuwait, Saudi Arabia, Australia, and Iraq.

Beginning in 1986, the tank was up-gunned to the Rheinmetall 120mm, also produced under license. Known as the M1A1, more than 5,000 of this variant were completed from 1986 to 1992.

The M1A2 is an improved M1A1 and features a thermal viewer for the commander, GPS navigation equipment, digital controls and displays, and an improved fire control system. The M1A2 SEP (System Enhancement Package) variant added digital maps and the integrated Force Battle Command Brigade software system which allows the commander to track friendly and hostile forces in real time. Improved thermal imaging and night vision was provided via upgrades to the existing thermal viewers. The armour was upgraded to third generation depleted uranium with a graphite coating. All the new computer equipment generated considerable extra heat, so the cooling system was also upgraded.

Experience with friendly fire incidents during the Gulf War and in Iraq led to the installation of Combat Identification Panels on the vehicle. Those on the side armour and the rear of the turret carry large unit numbers, the panels on the front of the turret are painted with a four-cornered 'box' image. Some of the tanks were equipped with a secondary storage bin fitted to the back of the existing rack on the rear of the turret for supplies and personal belongings.

The M1 in all its variations is expected to see front-line service until at least 2050.

### **The Kit:**

In 1/72 scale, the kit features the M1A2 SEP version with the Combat Identification Panels and the optional secondary storage bin on the rear of the turret.

#### **Packaging:**

The kit comes in a very well-constructed box with a lift-off lid featuring a painting of the tank in front of the infamous crossed swords and arms outside of Baghdad.

The side of the lid contains specifications for the M1A2 SEP and notes regarding its main features; the inner box has views of existing and upcoming Flyhawk warship and tank kits.

The kit comprises 143 parts on 19 sprues with a further 26 photo-etch parts. Eighteen of the sprues are moulded in medium grey with one sprue in clear plastic. All the kit components are sealed in plastic bags, including the decals and the photo-etch sheet. The tracks, mantlet, hull top, hull bottom, turret top and turret bottom are the only parts on their respective sprues.

**FLYHAWK®**

**FH 3300**

1/72 SCALE

# M1A2 SEP Main Battle Tank

M1A2 SEP 主戦坦克  
UNASSEMBLED MODEL KIT

Including PE  
エッチングパーツを含む  
青銅刻片

**FLYHAWK®**  
高品質模型 FLYHAWK MODEL  
中國製造 MADE IN CHINA

Add: #5-28 Building JunDuCaiShe,  
NO.293 KeYuan 6th Road,  
JiuLongPo District,  
ChongQing, China

地址: 重慶市九龍坡菜園壩六路293號  
郵政編碼400028-5

<http://www.flyhawkmodel.com>  
E-mail: flyhawkmodel@vip.163.com

The M1A2 System Enhancement Package (SEP) is a successor to the M1A2. The M1A2 SEP has a more advanced fire control system with upgraded ballistic computer. Both the gunner's sight and commander's independent thermal viewer use new 2nd generation FLIR technology and have improved thermal imaging and night vision capabilities. Commander and gunner can designate and track multiple targets simultaneously. This gives the tank a hunter-killer engagement capability. The M1A2 SEP main battle tank is the backbone of the US armored forces in 21st century in terms of a digitalized battlefield management system. M1A2 is the most advanced digitalized tank in US Active armored forces. M1A2 has participated Iraq War in 2003.

M1A2システム拡張パッケージ (SEP) は、M1A2の後継機種です。M1A2 SEPは、高度な弾道コンピュータを備えたことにより高度な砲火システムを導入しています。前線後の視界と司令官の独立したサーマルビューは、新しい2世代のFLIR技術を使用し、熟練者と戦闘能力の能力を向上させました。同時に指揮官は、複数のターゲットを同時に指定して追跡することができます。M1A2 SEPメイン主力戦車、21世紀の米軍装甲部隊のデジタル戦術システムのバックボーンです。M1A2は米国の装甲部隊の中で最も高度なデジタルタンクです。2003年のイラク戦争でこれらに参加を引き続き使用されています。

M1A2 SEP "艾布拉姆斯" 主戦坦克是M1主戦坦克的改进型號，裝備了二代熱成像系統，專長獨立熱成像儀，及夜視設備，數字化炮臺，熱成像熱像儀，新的數字化指揮，控制，通信設備，SEP增強式System Enhanced Package (系統增強包) 的設備。作為美國二十一世紀軍力計劃陸軍數字化戰場的核心，是美國最先進的數字化坦克，在2003年的伊拉克戰爭中也出現了活躍的後影。

Copyright © 2017  
All rights reserved by Flyhawk Models

6 492 1970 400468

性能諸元:  
最大速度: 68km/h  
オフロードスピード: 48km/h  
総重量: 49t  
全高: 4050mm  
主要武器: 120mm ガン  
7.62mm ガン  
12.7mm ガン

参数:  
最大速度: 68km/h  
越野速度: 48km/h  
行程: 450km  
全高: 4050mm  
主要武器: 120mm滑膛炮  
7.62mm機槍  
12.7mm機槍

1/700  
FH1109

HMS Penelope 1940  
coming soon

1/700  
FH1125  
HMS Warspite 1940

Global limited 1000 kits  
全球限量1000套

1/700  
FH1126

HMS Hermes 1937  
Coronation Fleet Review

1/72  
FH3003

Pz-Kpfw II Ausf L Luchs  
W Zusatzpanzerung

1/72  
FH3005

Pz-Kpfw II Ausf G (VK16.01)

1/72  
FH3013

French Streetscape

---- Box Art ----

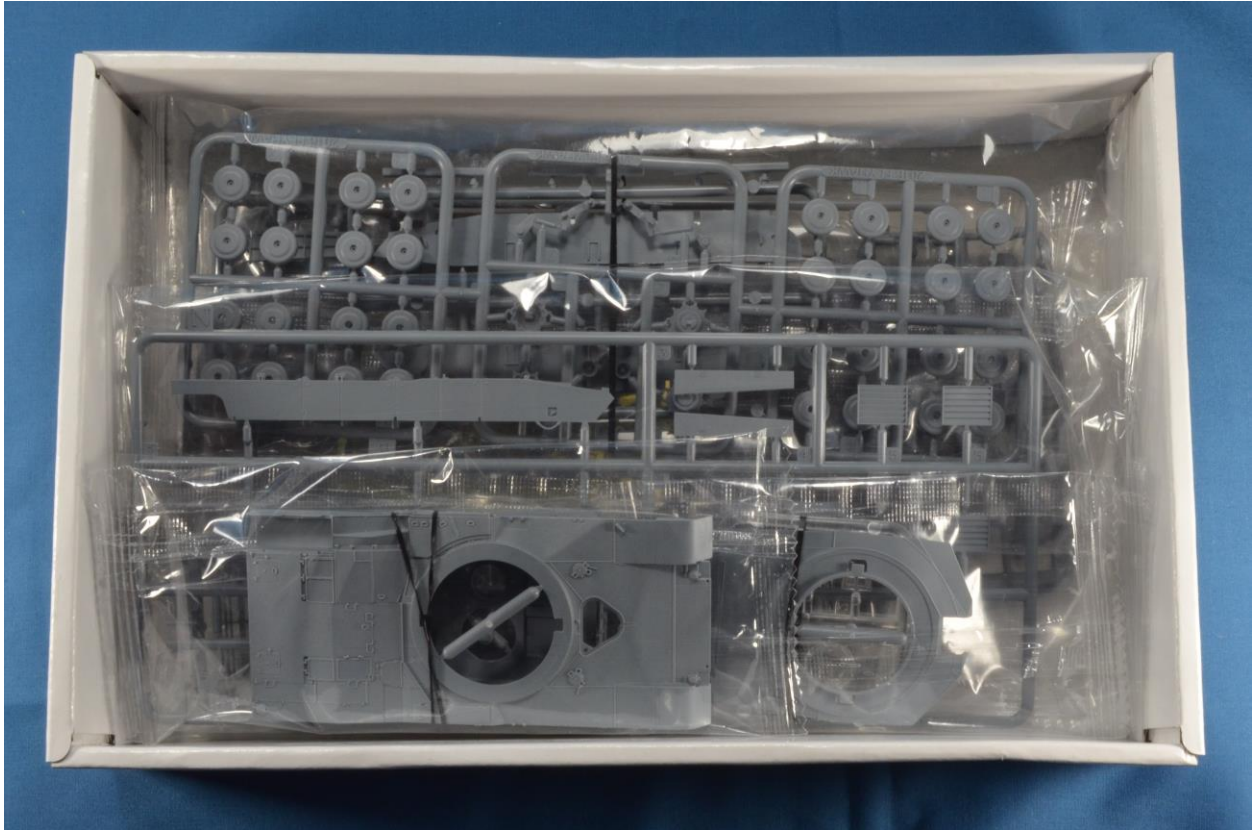

---- *Box contents* ----

Sprue A:

The M1A2 sports an inner and an outer track on each side of the hull and these are reproduced in the kit with four one piece tracks made from solid plastic; the inner set of tracks incorporating the 'teeth' that engage the drive sprockets. All four track pieces have very well defined track links.

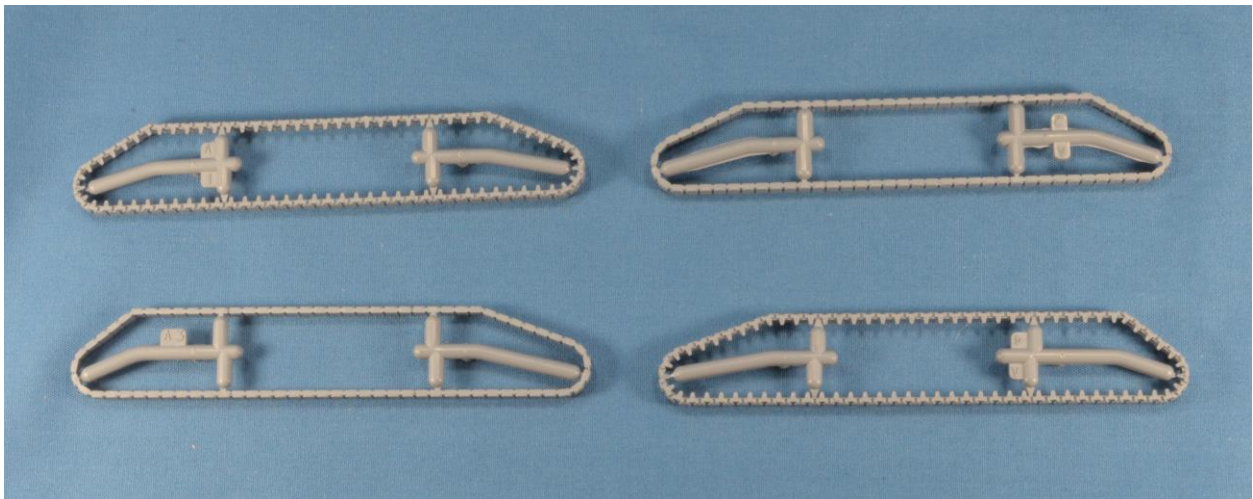

---- *Sprue A – inner tracks at top left and bottom right* ----

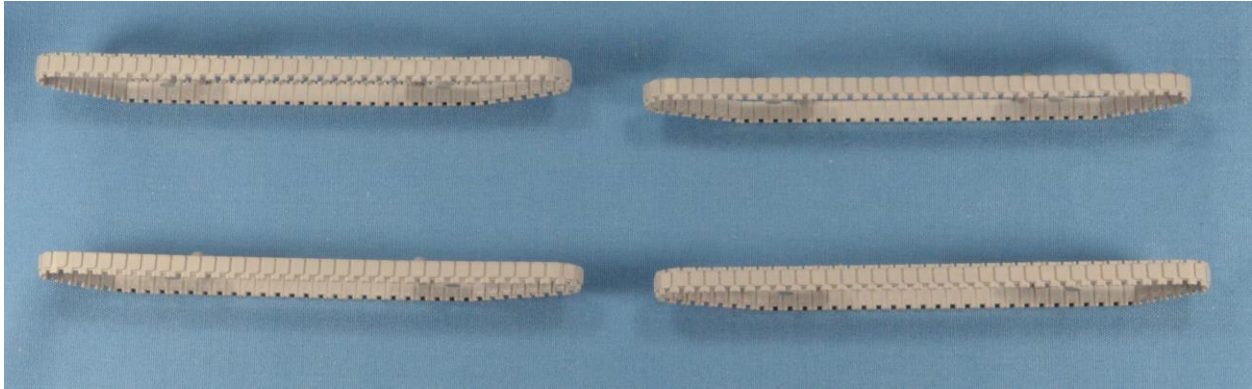

----- Sprue A – Overhead view showing the track links -----

Sprues B and C:

The road wheels are on sprue B. Each completed wheel is made up of inner and outer pieces which feature sharply defined lug nuts, bolts, and the rim of the rubber tire. There are two Sprue B's included.

Sprue C has the rear drive sprockets, idler wheels, and front road wheel suspension. The drive sprockets have an inner and outer portion featuring lug nuts and sharply defined teeth to grasp the inner tank track. The complex shape of the front road wheel suspension is very well executed.

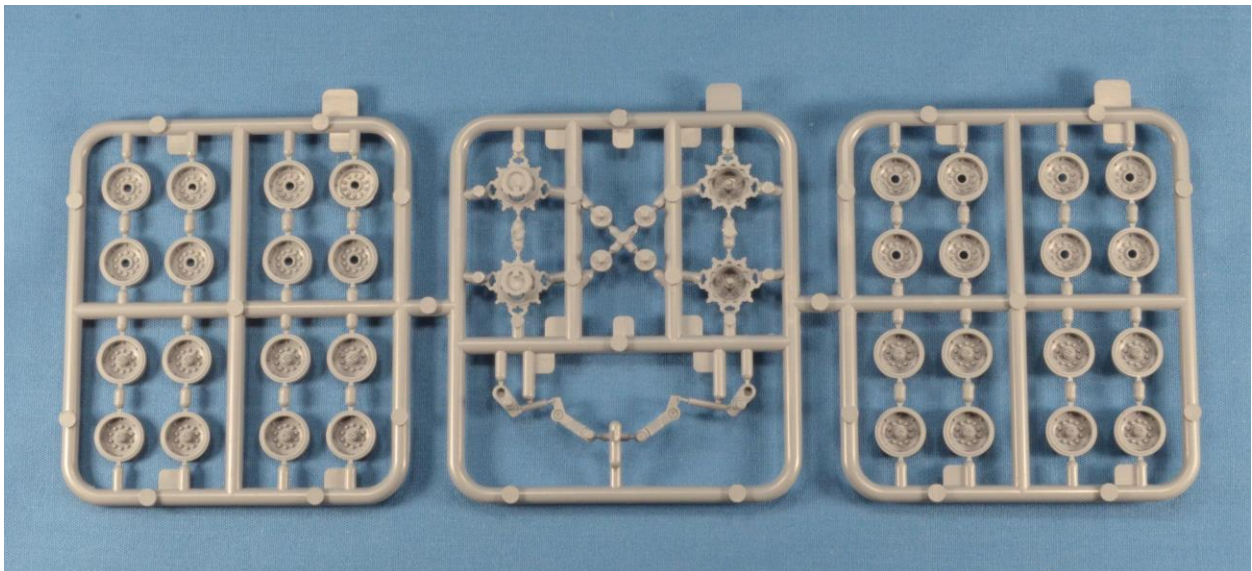

----- Sprues B and C -----

Sprue D:

This is the single piece that forms the bottom of the tank hull with six of the road wheel axles attached.

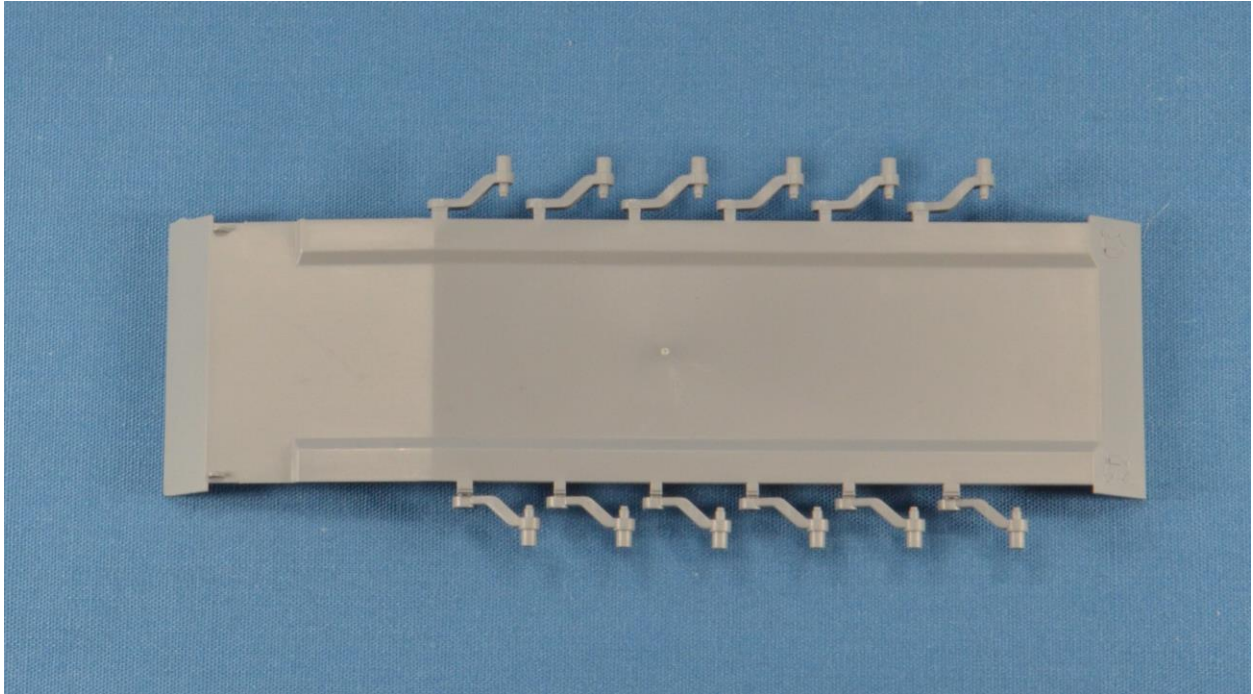

----- Sprue D – Hull bottom -----

Sprue E:

The hull sides are on this sprue and feature plenty of raised detail in the form of bolts, plates, and suspension arms. There are also 3 cross beams which will connect the hull sides together when assembling them to the hull bottom. This is a very good feature which will provide plenty of rigidity to the completed hull.

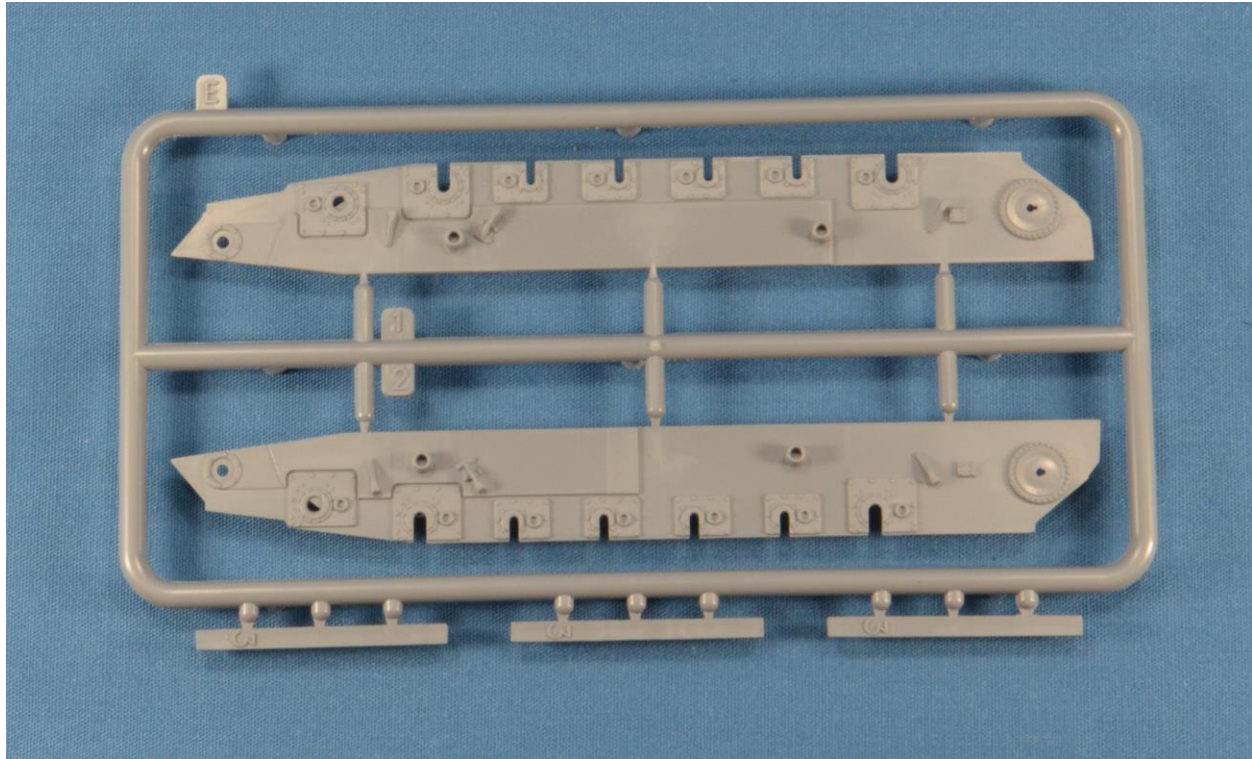

----- Sprue E – Hull sides -----

### Sprue F:

This is the single piece that forms the top of the hull and is an excellent example of the level of detail made possible with slide-mold technology. The top and sides are loaded with raised detail: hatches, raised and recessed hinges, raised and recessed panel lines, tie-downs, and raised plates are all crisply defined. The non-slip coating on most of the upper hull is also clearly evident. The complex shape of the upper hull with the distinctive step down forward of the turret and step up aft of the turret, and the sloping sides is well captured.

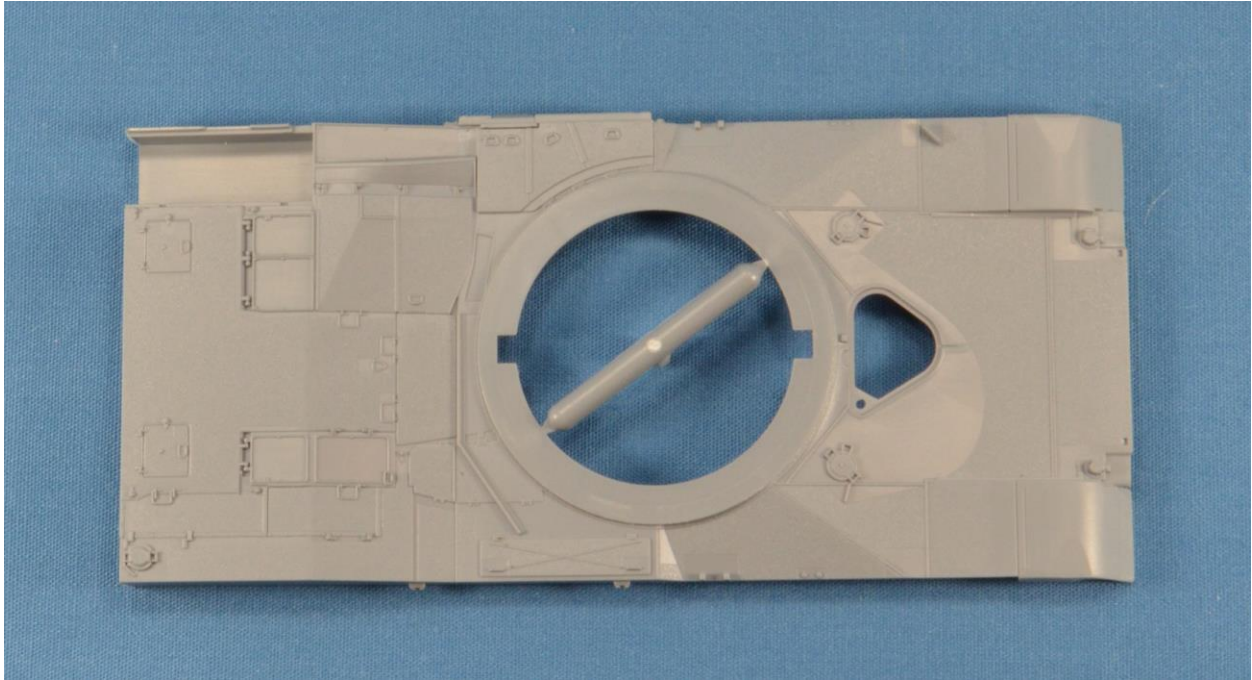

----- Sprue F – Hull top -----



### Sprues G and H:

These are the two pieces that make up the turret, sprue G being the bottom and sprue H the top. Both pieces feature plenty of detail: raised panel lines, compartment covers, tie down straps, tubing, and attach points for gear. The non-slip coating is also present on the turret top.

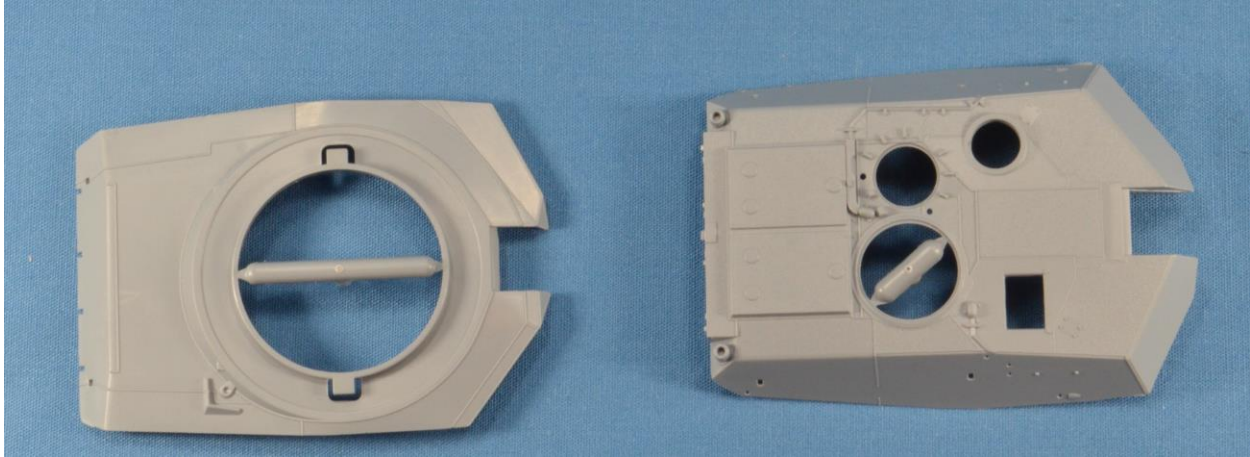

----- Sprue G (left) and Sprue H (right) -----

### Sprue I:

This is the single piece main gun mantlet. It is quite an incredible piece with a very complex shape, recessed panels, bolts, and the round protruding aperture for the main gun.

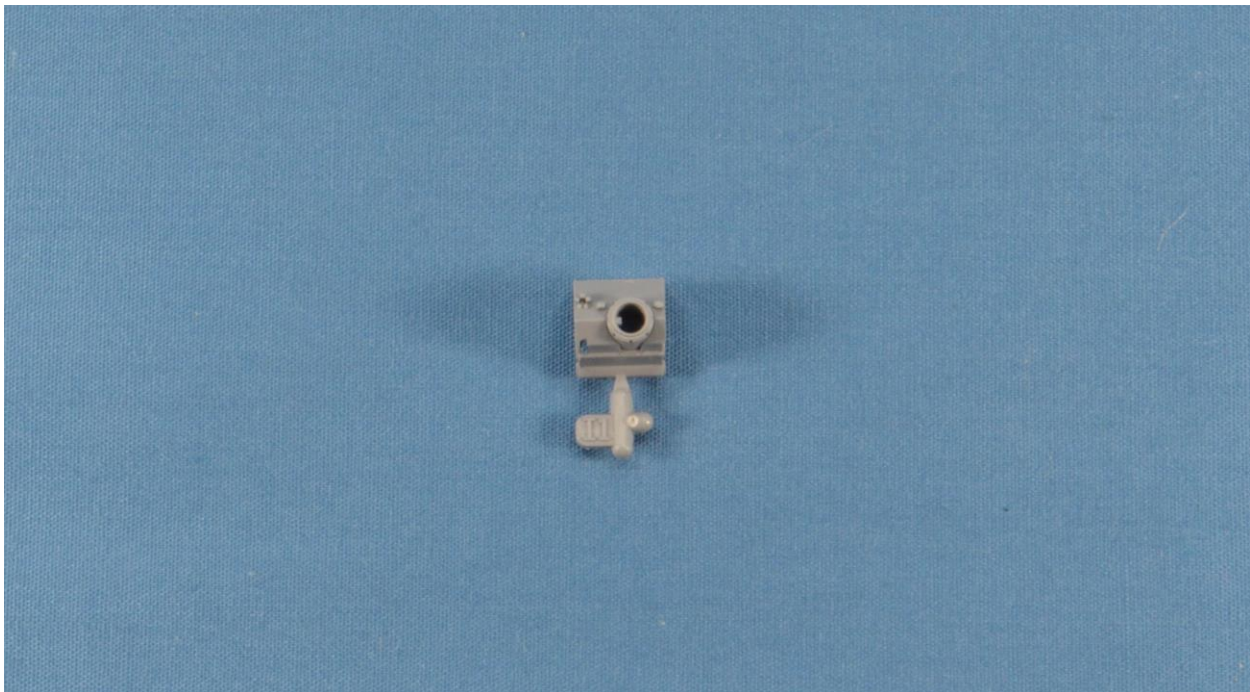

----- Sprue I – Main gun mantlet -----

Sprue J:

This sprue contains the pieces that make up the commander's and gunner's hatches on the top of the turret. Five of the pieces make up the commander's hatch; the gunner's hatch has four pieces. There is plenty of raised detail and the commander's hatch has the forward protruding machine gun mount. The commander's hatch can be assembled open or closed.

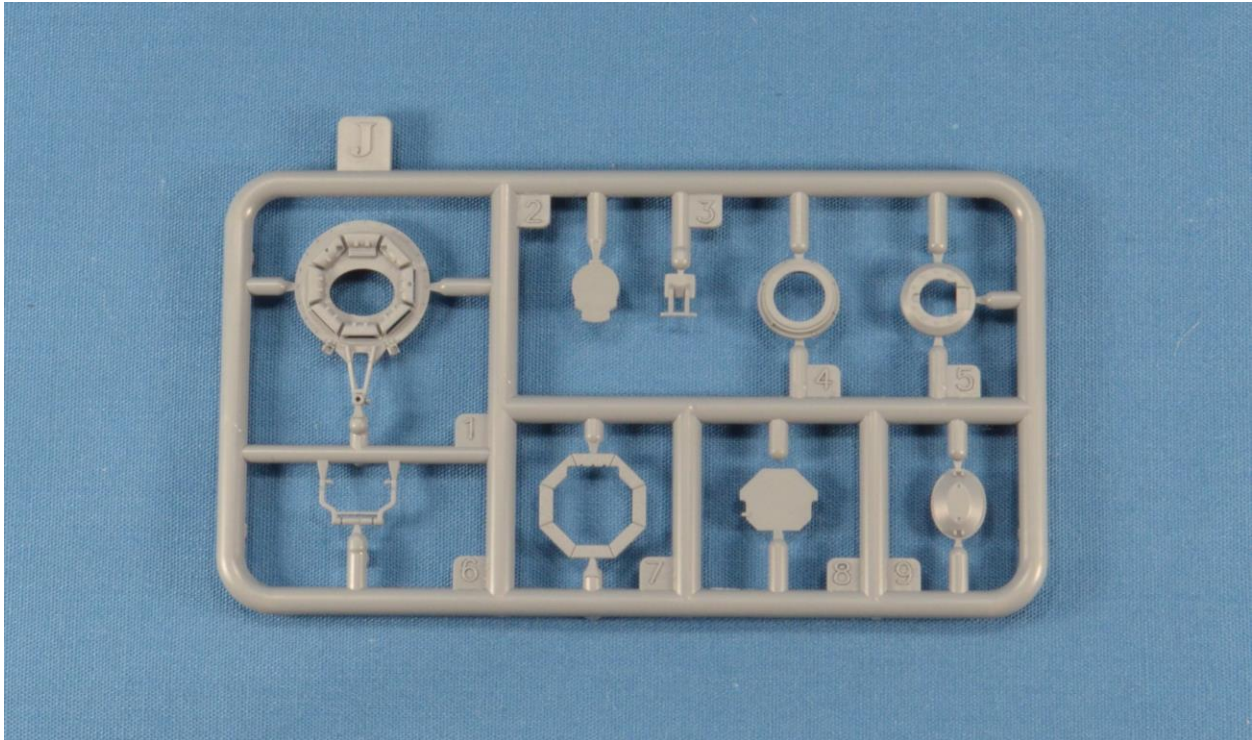

----- Sprue J – Turret hatch pieces -----

Sprue K:

This sprue has miscellaneous fittings including tow cables, the commander's turret machine gun, hatch covers, smoke grenade launchers, and the cages that fit on the sides and back of the turret. The level of detail is quite incredible: the machine gun ammunition box is open showing the individual rounds, the machine gun has raised and recessed panel lines and the jacket cooling holes, the tow cables are detailed on every side, the very complex shape of the grenade launchers is evident, and the open grill work on the cages is shaped perfectly. All of the smaller fittings also feature raised or recessed detail as appropriate.

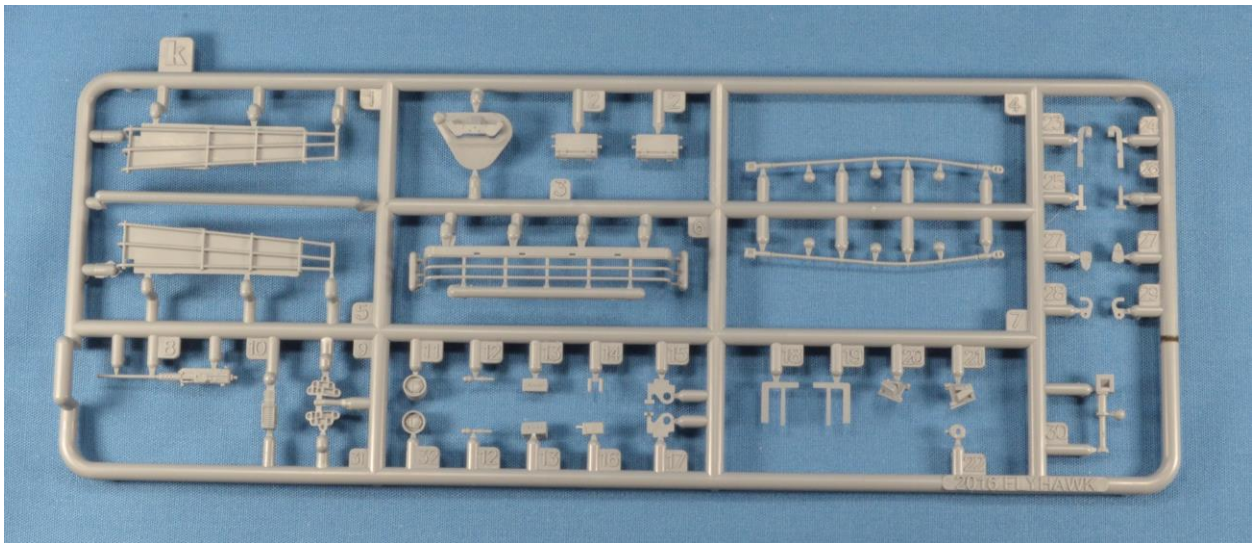

----- Sprue K -----

Sprue L:

This sprue contains the parts that make up the optional second cage that fits behind the turret along with some smaller fittings. The pieces for the cage are quite exceptional, with smooth curves, raised uprights, and a well-defined grill on the underside of the floor.

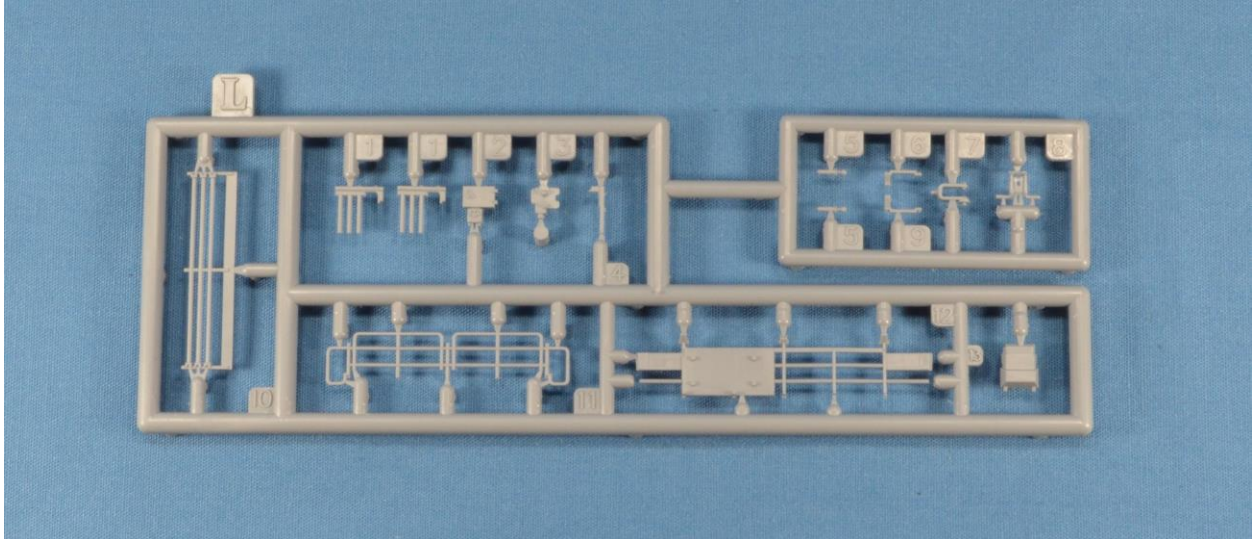

----- Sprue L -----

Sprue M:

Made from clear plastic, this sprue has clear vision ports for the commander's hatch, commander's vision port, gunner's hatch, loader's hatch, and the driver's hatch.

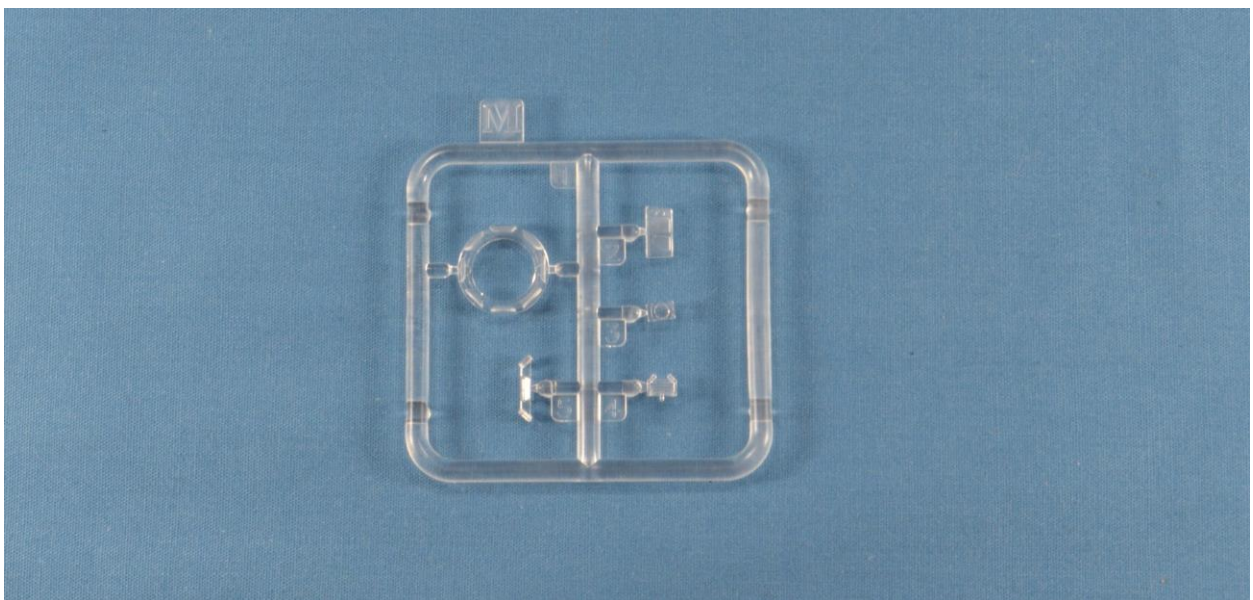

----- Sprue M – Clear plastic vision ports -----

Sprue N:

This sprue contains the side armour plates, rear hull plate, the 120mm main gun, the co-axial machine gun, the loader's hatch machine gun, and louvers for the external turret cages. The main gun is bored out and features raised rings and the characteristic 'hump' partway down the barrel, the side armour has recessed panel lines to delineate the individual plates, and the rear hull plate has raised grill work for the engine exhausts.

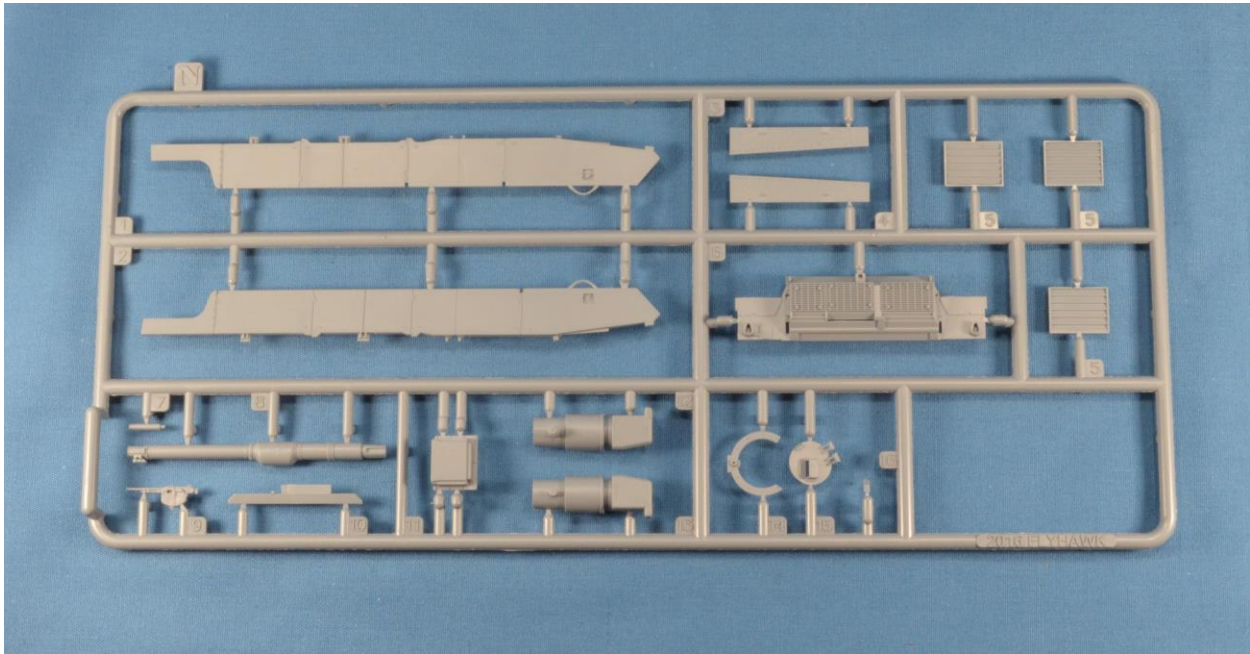

----- Sprue N -----

Sprue O:

This sprue has panels and armour plate for the top of the hull. Each piece is very detailed, the cover panel for the stowage bin has crisply executed handles and recessed panel lines.

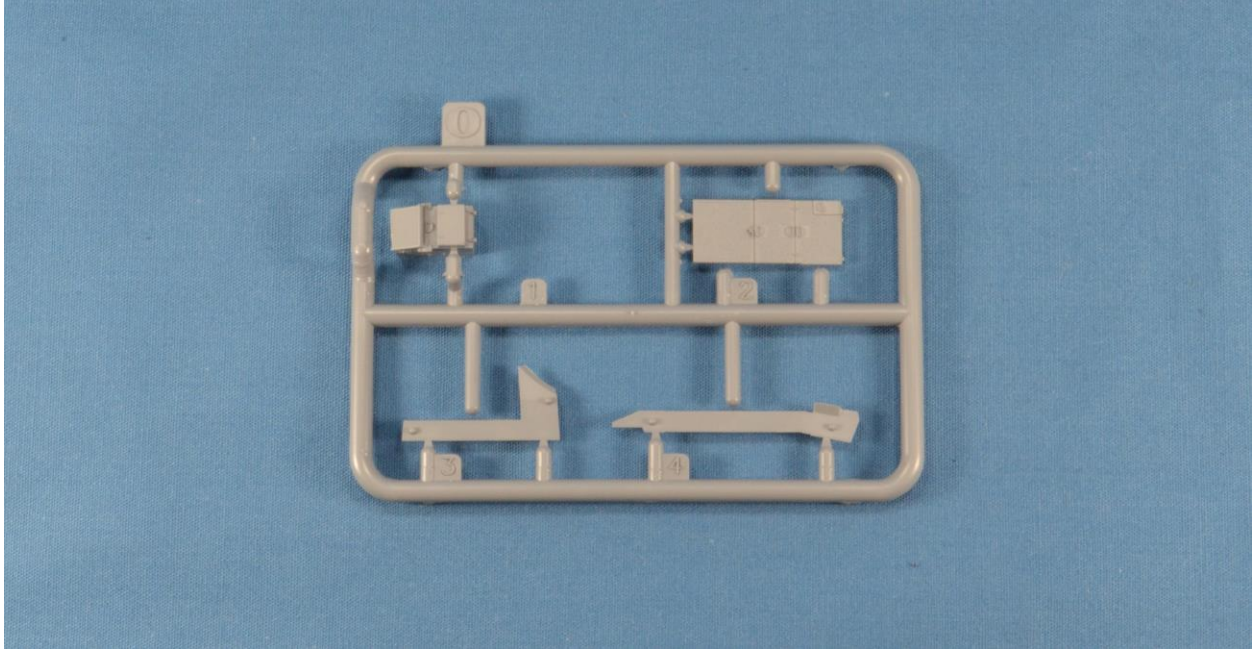

----- Sprue O -----

Decals:

Produced by the well-known Italian firm of Cartograf, the extensive decal sheet has the markings for five different vehicles. Full instructions on where to place the decals is shown on the painting and marking diagrams.

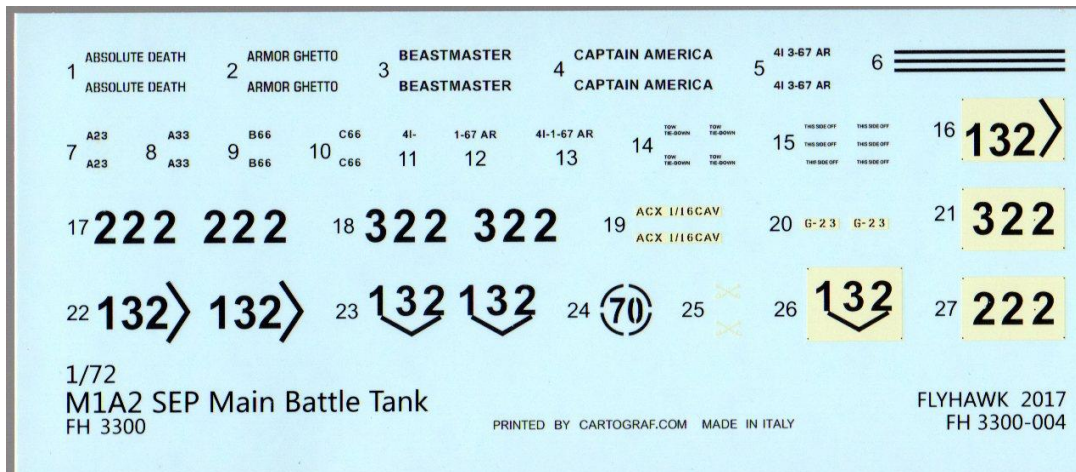

----- Decals -----

### Photo-Etch:

A very comprehensive photo-etch sheet is also included containing grillwork for the upper hull, external piping and handles for the front fenders, a top shield for the main gun, non-skid decking for the external turret cages, hatch handles, extensions for the turret viewing port, combat identification panels, and a small plate for the rear hull. There is also a set of numbers to be used for the individual tank number at the after end of the turret. As an aid for painting, an open circle that fits directly over the road wheel is also on the sheet, allowing the modeller to first paint the rubber tire, and then fit the circle over the wheel rim so that the wheel can be painted.

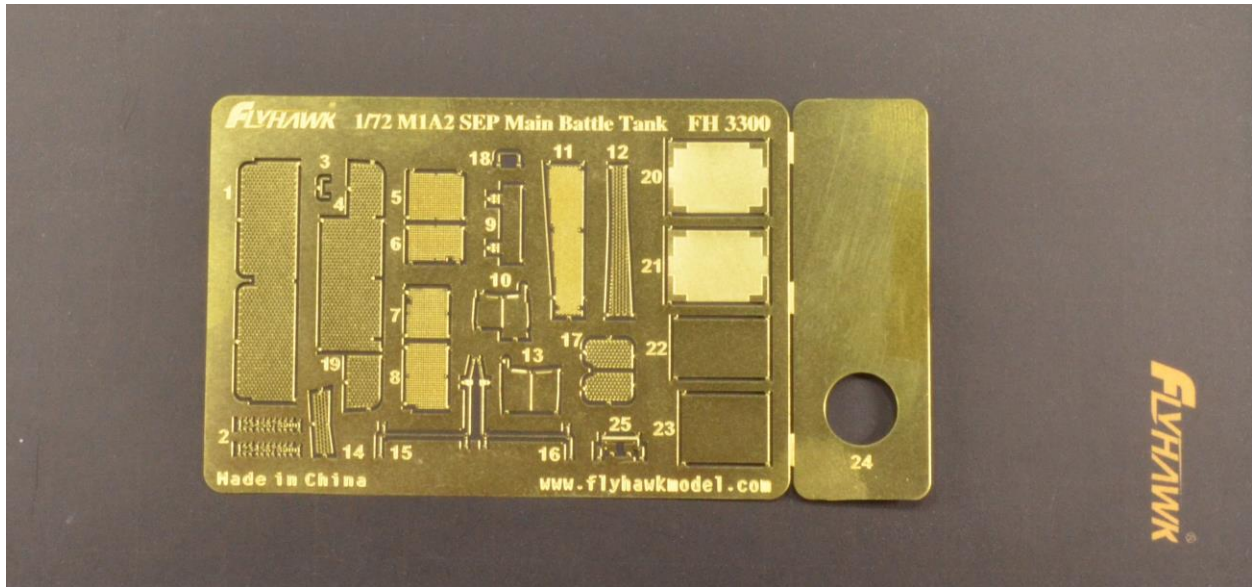

----- Photo-etch sheet -----

### Instruction Booklet:

A twelve page full colour booklet is included that contains a drawing of all the sprues included in the kit along with the decal and photo-etch sheets, the instructions, a colour guide, a drawing of an M1A2 in full camouflage, and photos of a completed model.

The instructions consist of six very clear and logical steps. Each step is well laid out with exploded views and sub-assemblies; modellers should have no problems understanding each step. Flyhawk uses colour coding to assist with placement of smaller parts and photo-etch; this is a very good feature which takes out a lot of guess work.



**FLYHAWK®**

**FH 3300 M1A2 SEP Main Battle Tank**  
**1/72 SCALE M1A2 SEP 主戰坦克 UNASSEMBLED MODEL KIT**

Including PE  
 エポキシパーツを含め  
 を収録

**PARTS**

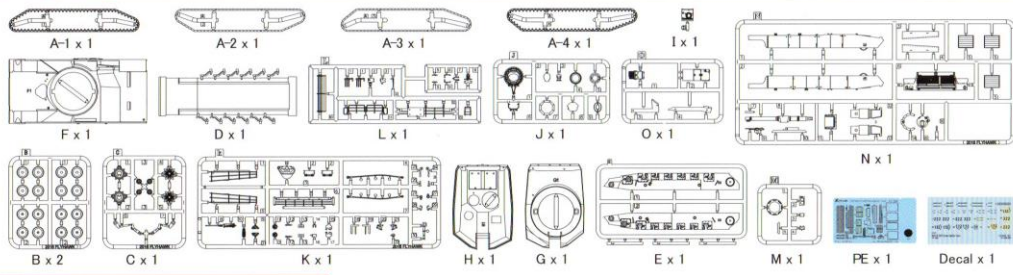

**READ BEFORE ASSEMBLING**

- Please check out the instruction before assembling.
- Glue and paint are not included.
- Glue, paint and other tools are not allowed to be reached by children.
- Please take care while using tools, glue and paint should be kept away from fire and be sure not working with models in confined chamber.
- The suite may contain metal parts, please be careful while working.
- 組み立て前説明書をよくお読みください。
- 本キットは接着剤とペンキを含みません。
- 接着剤とペンキと道具などを子供に接触しないでください。
- 工具を使用する時安全に注意し、接着剤とペンキは火種に近づかないでください。また、密封の場所で作成しないでください。
- 本キットは金属パーツがある可能ですから、制作する時気を付けてください。
- 組装前請仔細閱讀說明書。
- 本套件不含膠水和油漆。
- 膠水、油漆、工具等不可讓小孩接觸。
- 使用工具時請注意安全，膠水和油漆請勿靠近接觸火種，請勿在密封的地方制作模型。
- 套件中可能帶有金屬零件，請小心制作。

**ICON INSTRUCTION**

<p><b>CURVE</b>        弯曲        BIEGEN        FRISER        ROLLER        曲げてください。</p>	<p><b>REMOVE</b>        除去        ENTFERNEN        RETIRER        SEPARARE        取り除いてください。</p>	<p><b>OPTIONAL</b>        可選擇安裝        NACH BELIEBEN        FACULTATIF        FACOLTATIVO        どちらかを選択してください。</p>	<p><b>INSTANT GLUE FOR METAL</b>        金屬用快干膠        METALLKLEBER        COLLA A METAL INSTANTANEE        COLLA INSTANTANEA PER METALLO        瞬間接著劑 (金屬用)</p>	<p><b>BEND DOWN</b>        向下折彎        RICHTIG        AGGLUTINER VERS LE BAS        HACIA ABAJO FLECCION        下向きに曲げてください。</p>
<p><b>BE CAREFUL</b>        注意        HIER VORSICHT        FARE ATTENZIONE        USARE ATTENZIONE        注意してください。</p>	<p><b>BEND</b>        折彎        BITTE BIEGEN        PLIER EN VOUS PLAINT        PLEGARE        折り曲げてください。</p>	<p><b>2</b>        MAKE 2PCS        2 TEILE FERTIGEN        EFFICCIARE 2 PECCES        FARE DUE PEZZI        2つ製作してください。</p>	<p><b>APPLY DECAL</b>        貼上水貼        ANWENDEN        APPLICHER DECALCOMANIE        APPLICARE DECALCOMANIE        デカールを貼ってください。</p>	<p><b>BENT UPWARD</b>        向上折彎        NACH OBEN GEBOGEN        AGGLUTINER VERS LE HAUT        DOBLAR        上向きに曲げてください。</p>
<p><b>OPEN HOLE</b>        钻孔        OFFEN        FARE UN TROU        FORO APERTO        穴を開けてください。</p>	<p><b>FILL HOLE</b>        嵌平孔        SCHLIESSEN        BOUCHER LE TROU        CORDI PINGO        穴を埋めてください。</p>	<p><b>DO NOT CEMENT</b>        不要黏合        NICHT KLEBEN        NE PAS COLLER        NON INCOLLARE        接着しないでください。</p>	<p><b>THE SAME MANUFACTURING ON THE OTHER SIDE</b>        另一側相同制作        DAS GLEICHE HERSTELLUNGSVERFAHREN AUF DER ANDEREN SEITE        LA FABRICATION MÊME DE L'AUTRE CÔTÉ        LA FABRICACIÓN DEL MISMO EN EL OTRO LADO        もう一方の側にも同じ製作</p>	



1



Avoid touching the small accessories on the turret so as to keep them from being fractured.  
製品の細部品に注意してください。触ると部品が折れる可能性があります。  
注意產品的小零件，避免因觸碰導致的損壞。

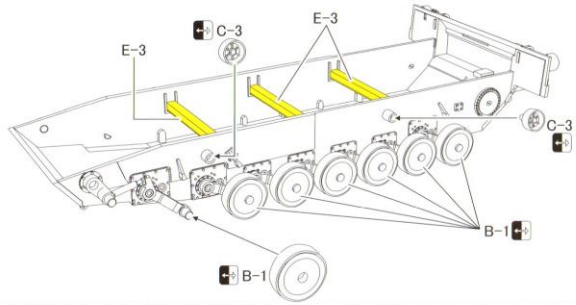
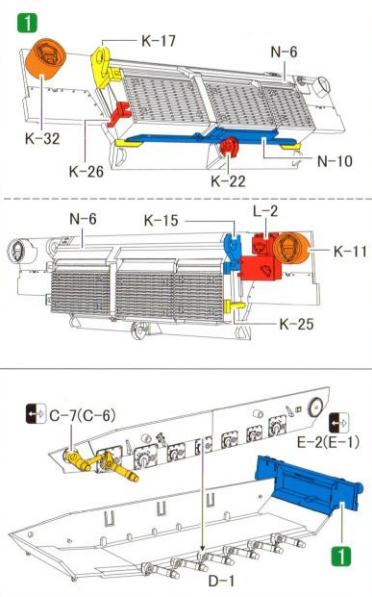

Please make sure the pedrail is well inserted and jointed before welding.  
まずキャタピラーが偽組してから、間違いないと塗装します。  
製作履帯前請注意假組確定後再進行後續操作。

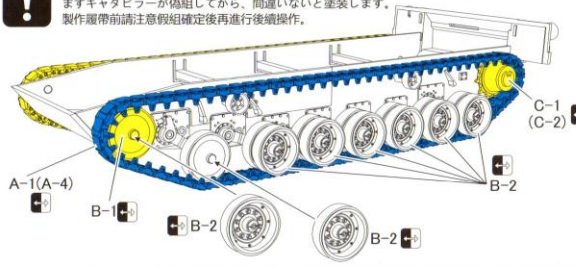

01

2



Please drill holes before building model.  
制作前にボーリングしてください。  
製作前請根據提示鑽孔。

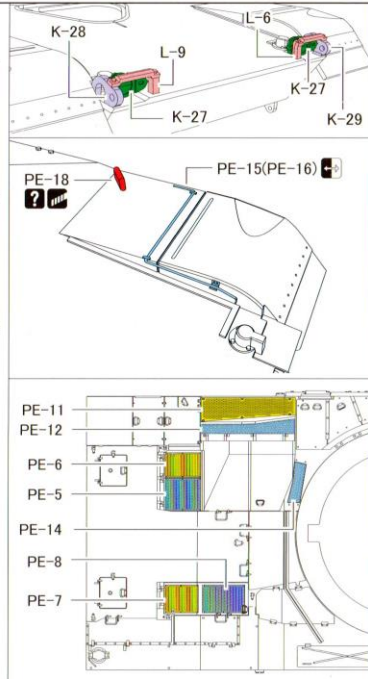
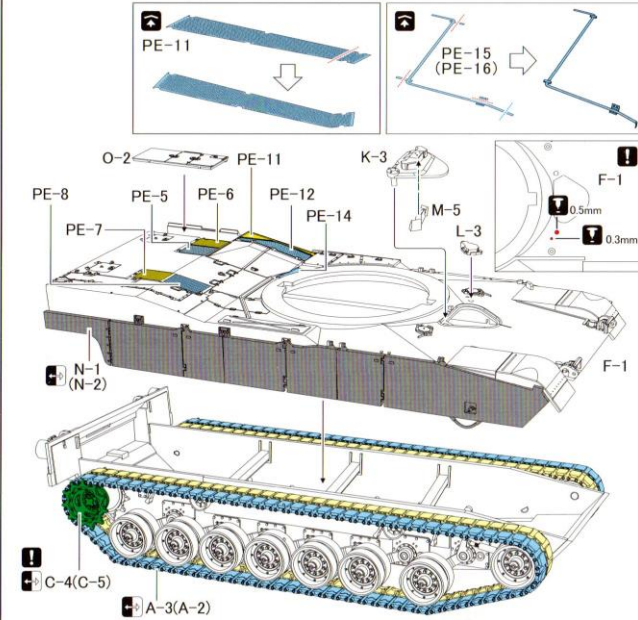

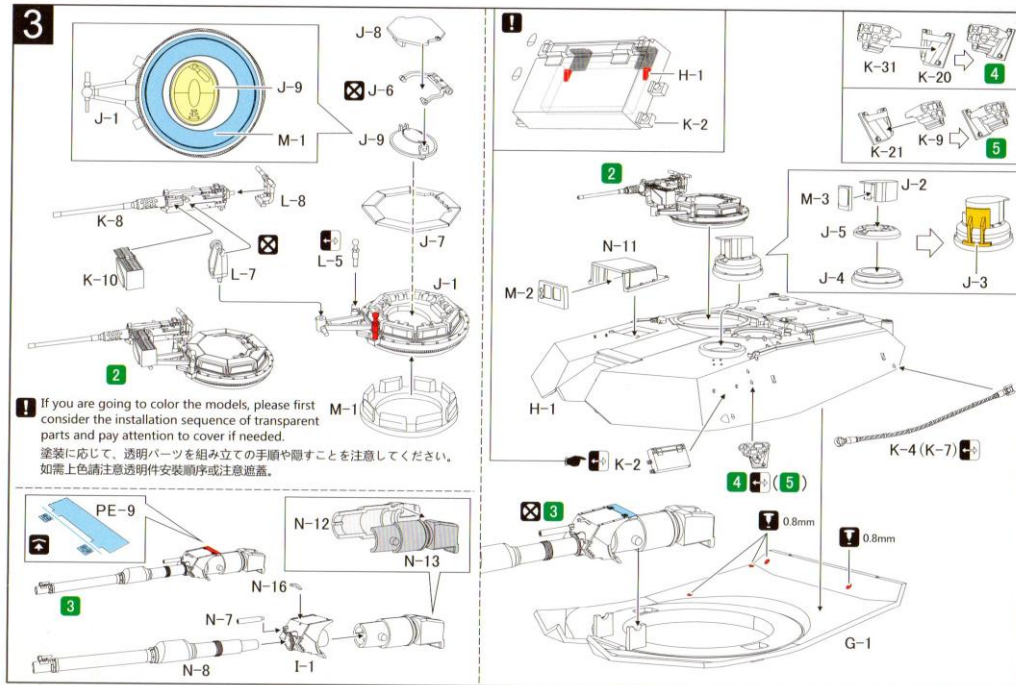

02-03

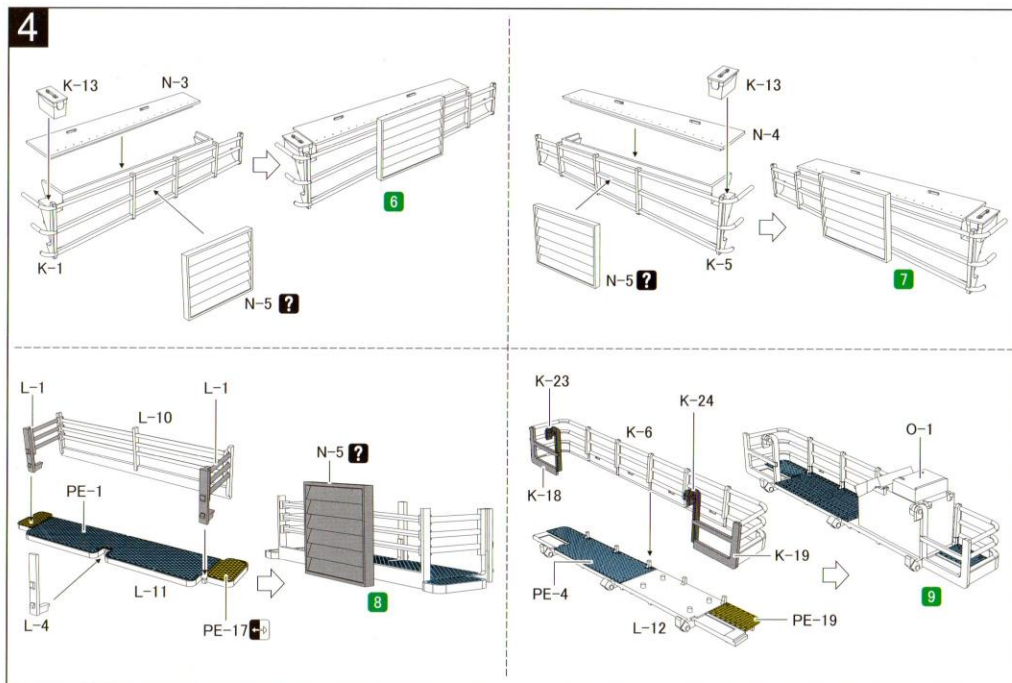

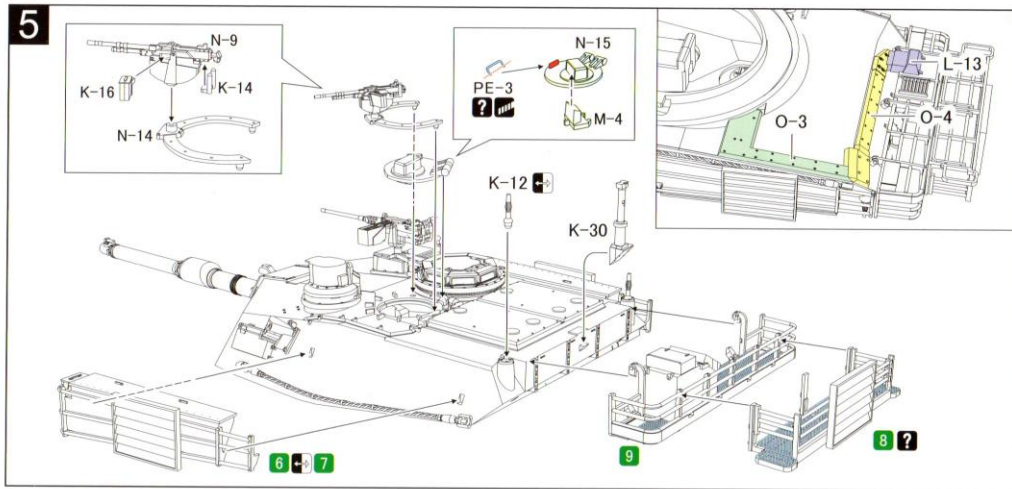

**!** Avoid touching the small accessories on the turret so as to keep them from being fractured.  
製品の細部品に注意してください。触ると部品が折れる可能性があります。  
注意: 製品の小零件, 避免因觸碰導致的損壞。

**!** Please use primer first before coloring photo-etched sheets.  
エッチングパーツを塗装する前に特殊塗料を使ってください。  
蝕刻片上色前請使用專用底漆。

**!** If you are going to color the models, please first consider the installation sequence of transparent parts and pay attention to cover if needed.  
塗装に応じて、透明パーツを組み立ての手順や隠すことを注意してください。  
如需上色請注意透明件安裝順序或注意遮蓋。

04-05

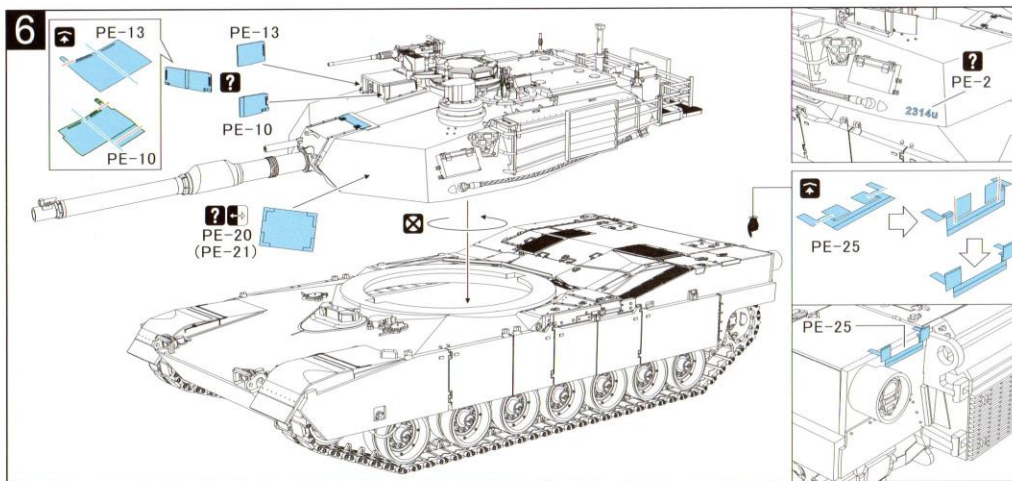

**PAINTING & MARKING GUIDE**

**Decal Application:**

1. Cut the pictures from sheet as needed.
2. Dip the pictures in warm water for about 10 seconds.
3. Hold the picture backing sheet edge and gently slide the picture onto the model.
4. Please move the picture to the proper position on model.
5. Please gently press picture down with a soft cloth until excess water's out and no air bubbles.

**塗装とデカールの指示**

**デカールの巻用方法**

1. マークをはみなどで切り取ります。
2. 切り取ったマークをぬるま湯に10秒ほどひたします。
3. マークは台紙ごと貼りたい位置に移動して、マーク部分のみをスライドさせて下さい。
4. 柔らかい布などでマークをおさえて気泡や水分をとってください。

**塗装與標貼指示**

**水貼紙的使用:**

1. 從水貼紙上剪下圖案;
2. 將圖案放入溫水中浸泡10秒;
3. 拿背圖紙面紙將圖案移動到模型上;
4. 將圖案移動到適當的位置;
5. 用軟布輕輕圖案直至水乾, 消除掉氣泡。

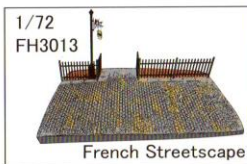

**FH 1117** **HMS Prince of Wales**  
**1/700 SCALE** UNASSEMBLED MODEL KIT











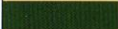

Copyright©2017  
All rights reserved by Flyhawk Models

FH 3300-003

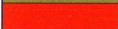
----- Instruction booklet -----

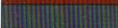
Colour scheme:

A colour guide is included in the instruction booklet with paint references for the AK Interactive range. The colours are clearly labelled which will allow the modeller to easily choose correct colours from a different range if necessary. Full colour painting and decal placement instructions are on the bottom of the box; as noted above there is a full colour camouflage scheme and decal placement drawing on one page of the instruction booklet.

	N°	Color	色	颜色
	AK122	OIF & OEF US Vehicles Base colour	イラク、アフガニスタン戦争米軍車輛基本色	伊拉克、阿富汗戦争米軍車輛基礎色
	AK796	NATO Green	NATOグリーン	北約緑
	AK137	Olive Drab Shine	オリーブドラブシャイ	美軍機機緑照耀色
	AK265	Clear Red	クリアーレッド	透明紅
	AK797	NATO Brown	NATOブラウン	北約棕
	AK798	Gun Metal	ガンメタル	槍鐵色
	AK720	Rubber / Tires	ラバー/タイヤブラック	橡膠輪胎黑色
	AK799	NATO Black	NATOブラック	北約黑色
	AK722	Dark Tracks	ダークトラック	深履帯色
	AK3035	Silver & Metal Midtones	シルバー&メタルミッドトーン	銀色&金屬色中間色

**!** Please use Photo-etch code no. PE-24 as paint mask when coloring  
 PE-24を使って、塗装を覆い隠します  
 請使用PE-24號零件輔助上色。

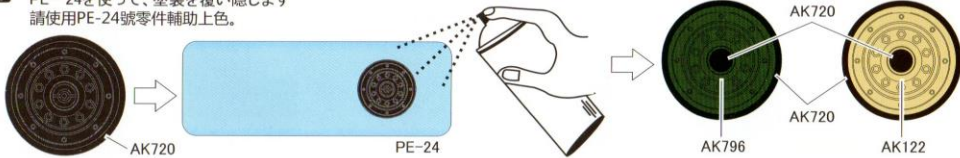

**!** AK3035 AK265 M-1 AK265 M-5  
 K-27 Body Color 車體色 K-32 (K-11)  
 M-2 M-3 M-4 Body Color 車體色  
 N-5 Body Color 車體色  
 AK122 AK137  
 PE-20(PE-21) Body Color 車體色

**06-07**

**A** 1st Btl., 16th Cav. Rgt., Fort Knox, Kentucky, USA 2002  
 第16騎兵連隊第1大隊 ケンタッキー州 フォートノックス駐屯地 2002年

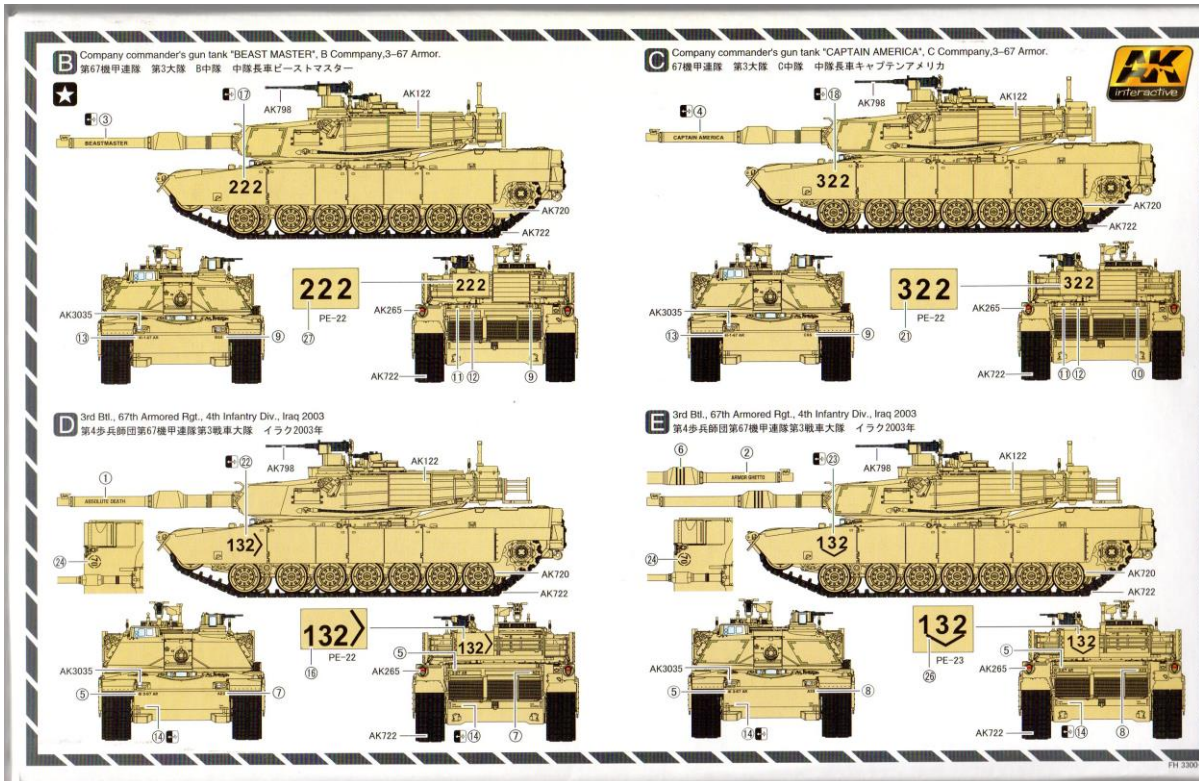
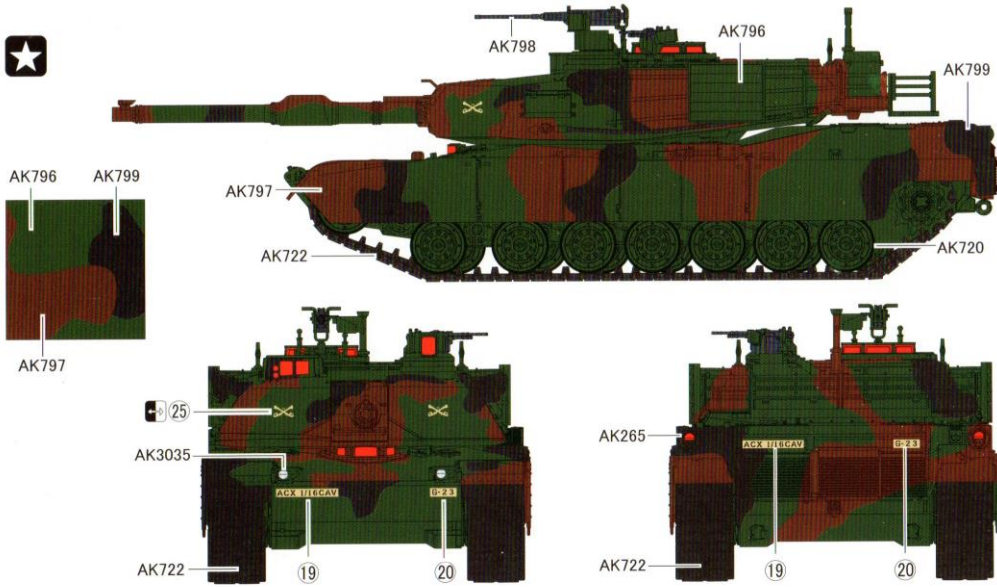

----- Colour guide and colour schemes -----

### Overall Impression:

This is quite an incredible kit, 160+ parts making up a model just 4" x 2". The level of cast-in detail is superb, with recessed and raised panel lines, handles, hinges, and bolts to name just a few. There is absolutely no flash on any of the pieces and none of those lines that result when two mould halves are used to make a single component.

The number of parts does not mean that the kit is 'over-engineered'. Many of the complex components are in one piece, such as the gun mantlet and the grenade launchers; the hull is made up of only four parts. The large part count is mainly due to the amazing level of detail found in the hatches, stowage bins, and the road wheels.

The fit on the parts that I dry-fitted was extremely precise, very little filling, if any, will be required to hide any seams. The plastic is also very robust; it bends easily rather than breaking. The large number of parts should not deter any modellers, the smallest pieces are substantial and the instructions are very easy to follow. The only things that could be added are the whip antennas at the rear of the turret; these can easily be made from stretched sprue and attached to the antenna bases which are present in the kit.

This is a highly recommended kit and it will make an eye-catching part of any collection, even for those used to building in larger scales. It really captures the hulking brute that is the M1A2 Abrams. The kit is an impressive addition to the Flyhawk 1/72 armour range; I'm eagerly waiting for the next in line!

*Review kit courtesy of Flyhawk Models*